

EDITION / VERSİYON
04/2019

SLIDING SYSTEM
SÜRME SİSTEMİ

SYSTEM 38C
SİSTEM 38C



38C SYSTEM / SİSTEM
TECHNICAL INFORMATION / TEKNİK BİLGİLER

System Properties / Sistem Özellikleri

Frame Height / Kasa Geniřliđi : 63 mm
 Vent Height / Kanat Geniřliđi : 38 mm
 Wall Thickness / Et Kalınlıđı : 1.4

Safety Drainage System / Güvenli Tahliye Sistemi

EPDM Gaskets / EPDM Fıtil

Glazing From 4 mm to 24 mm
 Cam Kullanımı 4 mm'den 24 mm

Code Logic / Kod Mantıđı

38C	101	00
Title/Seri	Group/Grup	Factory Standard Fabrika Standardı

Titles / Seriler

38C - System Name / Sistem Adı
 08 - Glazing Bead / Cam Çırtası
 09 - Extruded Corner Joints / Pres Köşe Takozu

Groups / Gruplar

101, 102, ... Frames / Kasalar
 201, 211, ... Vents / Kanatlar
 501, 502, ... Adapters / Adaptörler
 801, 802, ... Glazing Beads / Cam Çırtası

Alloy / Alařım

The alloys of the aluminium profiles are 6060 and 6063 (AlMgSi 0,5 - F22) based on EN 12020-2 / 755-9 standards. Alüminyum profil alařımları 6060 ve 6063 (AlMgSi 0,5 - F22) EN 12020-2 / 755-9 standartlarına uygundur.

All drawings are not scaled.
 Tüm çizimler ölçeksizdir.

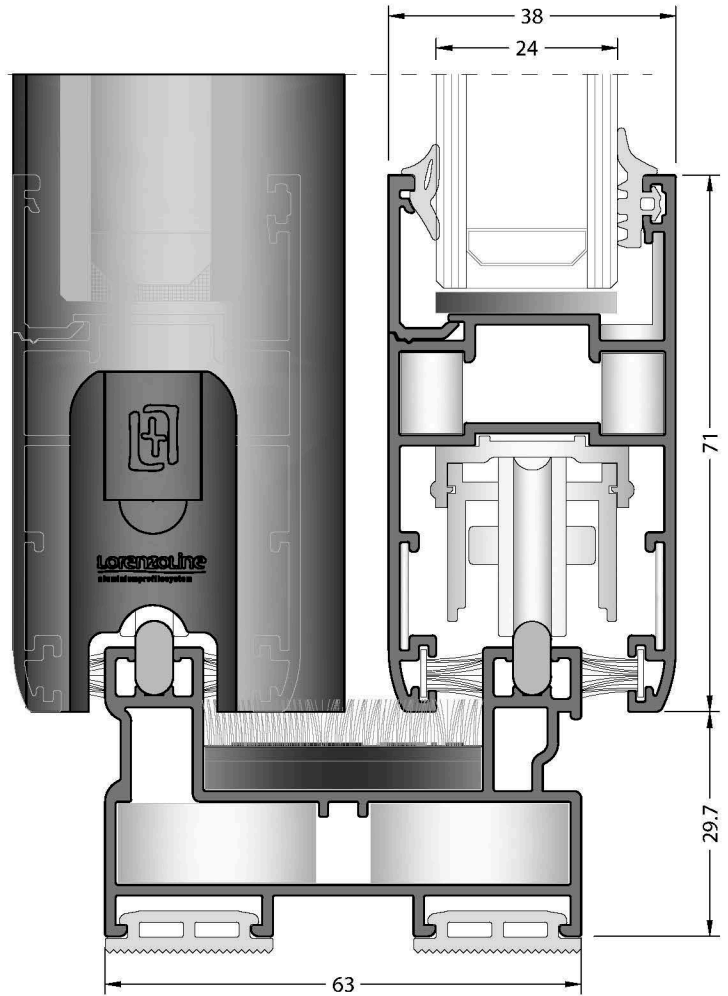
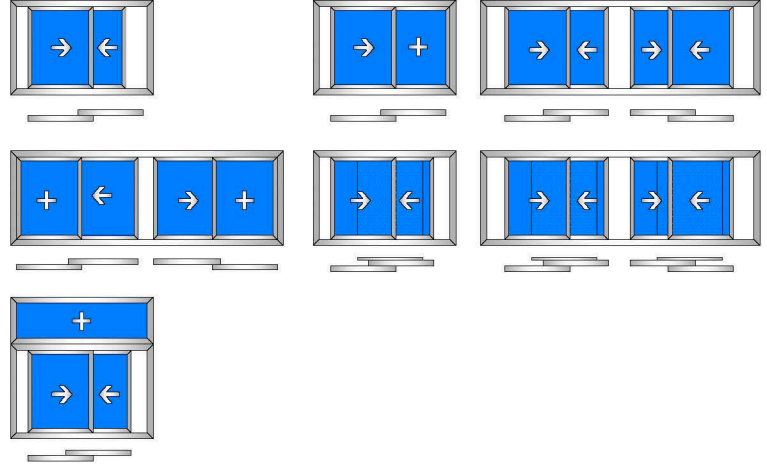
Sliding Opportunities / Sürme Seçenekleri

**38C SYSTEM / SİSTEM
PROFILES / PROFİLLER**

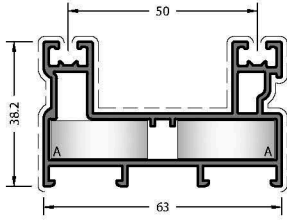

CODE / KOD
38C-101-00

THEORETICAL WEIGHT kg/m
TEORİK AĞIRLIK kg/m
1.086

CORNER JOINTS
KÖŞE BAĞLANTILAR

A CC-101-26.3

DIE-CAST CORNER JOINTS
PİMLİ BAĞLANTILAR

A LC-1127

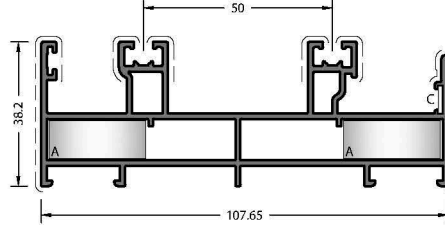

CODE / KOD
38C-132-00

THEORETICAL WEIGHT kg/m
TEORİK AĞIRLIK kg/m
1.690

CORNER JOINTS
KÖŞE BAĞLANTILAR

A CC-101-26.3

C LC-107

DIE-CAST CORNER JOINTS
PİMLİ BAĞLANTILAR

A LC-1127

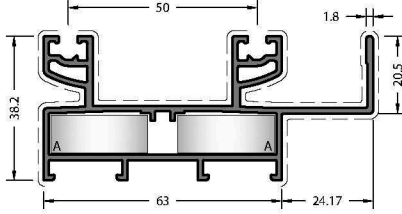

CODE / KOD
38C-122-00

THEORETICAL WEIGHT kg/m
TEORİK AĞIRLIK kg/m
1.318

CORNER JOINTS
KÖŞE BAĞLANTILAR

A CC-101-26.3

DIE-CAST CORNER JOINTS
PİMLİ BAĞLANTILAR

A LC-1127

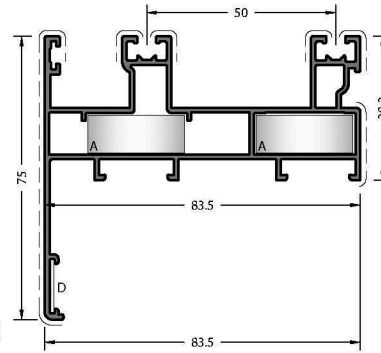

CODE / KOD
38C-162-00

THEORETICAL WEIGHT kg/m
TEORİK AĞIRLIK kg/m
1.425

CORNER JOINTS
KÖŞE BAĞLANTILAR

A CC-101-26.3

D MK-20.1

DIE-CAST CORNER JOINTS
PİMLİ BAĞLANTILAR

A LC-1127

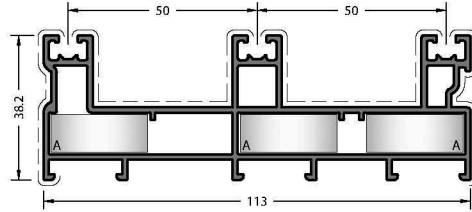

CODE / KOD
38C-103-00

THEORETICAL WEIGHT kg/m
TEORİK AĞIRLIK kg/m
1.779

CORNER JOINTS
KÖŞE BAĞLANTILAR

A CC-101-26.3

DIE-CAST CORNER JOINTS
PİMLİ BAĞLANTILAR

A LC-1127

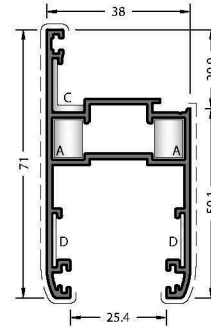

CODE / KOD
38C-201-00

THEORETICAL WEIGHT kg/m
TEORİK AĞIRLIK kg/m
0.950

CORNER JOINTS
KÖŞE BAĞLANTILAR

A CC-101-08.2

C EM38-21

D MK-20.1

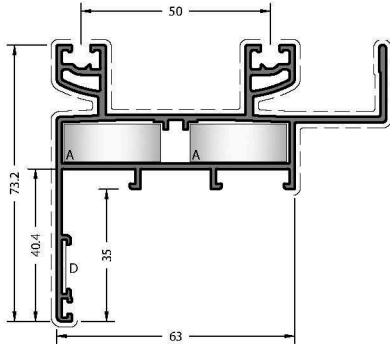

CODE / KOD
38C-123-00

THEORETICAL WEIGHT kg/m
TEORİK AĞIRLIK kg/m
1.478

CORNER JOINTS
KÖŞE BAĞLANTILAR

A CC-101-26.3

D MK-20.1

DIE-CAST CORNER JOINTS
PİMLİ BAĞLANTILAR

A LC-1127

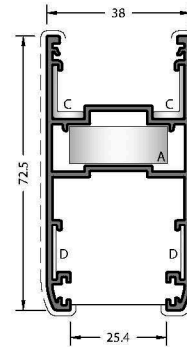

CODE / KOD
38C-202-00

THEORETICAL WEIGHT kg/m
TEORİK AĞIRLIK kg/m
1.071

CORNER JOINTS
KÖŞE BAĞLANTILAR

A CC-101-26.3

C EM38-21

D MK-20.1

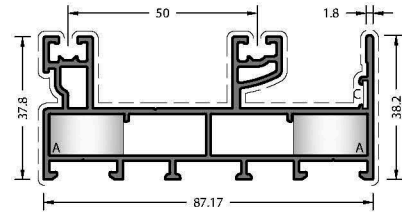

CODE / KOD
38C-124-00

THEORETICAL WEIGHT kg/m
TEORİK AĞIRLIK kg/m
1.509

CORNER JOINTS
KÖŞE BAĞLANTILAR

A CC-101-19.5

C LC-107

DIE-CAST CORNER JOINTS
PİMLİ BAĞLANTILAR

A LC-1120

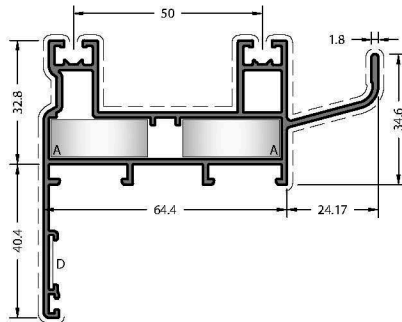

CODE / KOD
38C-131-00

THEORETICAL WEIGHT kg/m
TEORİK AĞIRLIK kg/m
1.402

CORNER JOINTS
KÖŞE BAĞLANTILAR

A CC-101-26.3

D MK-20.1

DIE-CAST CORNER JOINTS
PİMLİ BAĞLANTILAR

A LC-1127

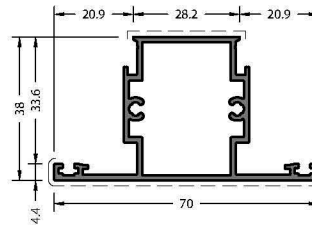

CODE / KOD
38C-302-00

THEORETICAL WEIGHT kg/m
TEORİK AĞIRLIK kg/m
0.831

CORNER JOINTS
KÖŞE BAĞLANTILAR

A CC-101-26.3

C EM38-21

D MK-20.1

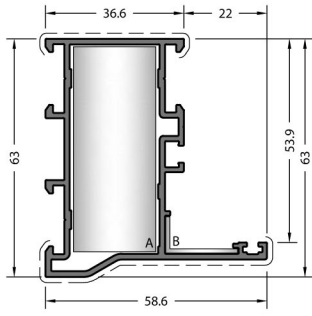

CODE / KOD
58C-108-15

THEORETICAL WEIGHT kg/m
TEORİK AĞIRLIK kg/m
1.057

CUTTED CORNER JOINTS

KESİLMİŞ KÖŞE BAĞLANTILAR



DIE-CAST CORNER JOINTS

PİMLİ BAĞLANTILAR



Application Details / Uygulama Detayı

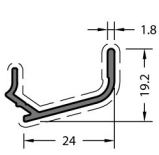
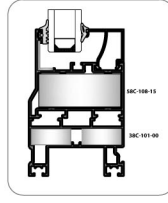

CODE / KOD
38C-510-00

THEORETICAL WEIGHT kg/m
TEORİK AĞIRLIK kg/m
0.210

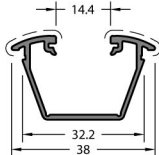

CODE / KOD
38C-513-00

THEORETICAL WEIGHT kg/m
TEORİK AĞIRLIK kg/m
0.320

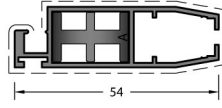

CODE / KOD
1621

THEORETICAL WEIGHT kg/m
TEORİK AĞIRLIK kg/m
0.498

CORNER JOINTS
KÖŞE BAĞLANTILAR



CODE / KOD
38-801-00

THEORETICAL WEIGHT kg/m
TEORİK AĞIRLIK kg/m
0.133

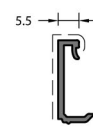

CODE / KOD
38-802-00

THEORETICAL WEIGHT kg/m
TEORİK AĞIRLIK kg/m
0.141

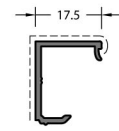

CODE / KOD
38-807-00

THEORETICAL WEIGHT kg/m
TEORİK AĞIRLIK kg/m
0.184

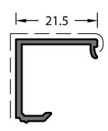

CODE / KOD
38-808-00

THEORETICAL WEIGHT kg/m
TEORİK AĞIRLIK kg/m
0.197

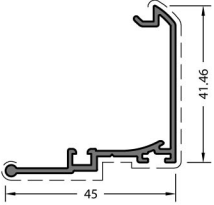

CODE / KOD
38-502-00

THEORETICAL WEIGHT kg/m
TEORİK AĞIRLIK kg/m
0.425

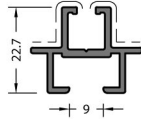

CODE / KOD
38-503-00

THEORETICAL WEIGHT kg/m
TEORİK AĞIRLIK kg/m
0.371



20 Micron Anodized.
20 Mikron Eloksal.

CODE / KOD
13-134-050R

THEORETICAL WEIGHT kg/m
TEORİK AĞIRLIK kg/m
0.118

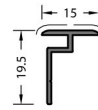

CODE / KOD
07-201-00

THEORETICAL WEIGHT kg/m
TEORİK AĞIRLIK kg/m
0.118

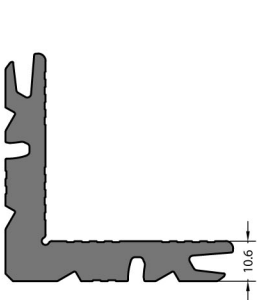

Mill Finish / Pres
No visible surface. / Görünen yüzeyi yoktur.

CODE / KOD
09-101-00

THEORETICAL WEIGHT kg/m
TEORİK AĞIRLIK kg/m
2.561

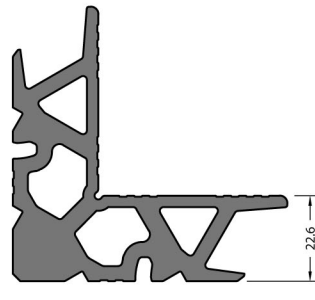

Mill Finish / Pres
No visible surface. / Görünen yüzeyi yoktur.

CODE / KOD
09-103-00

THEORETICAL WEIGHT kg/m
TEORİK AĞIRLIK kg/m
3.689

**38C SYSTEM / SİSTEM
DETAILS / DETAYLAR**

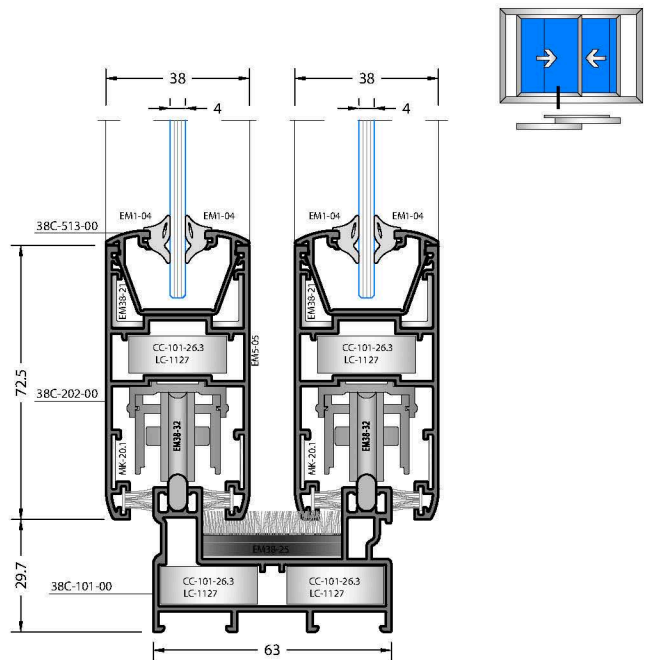
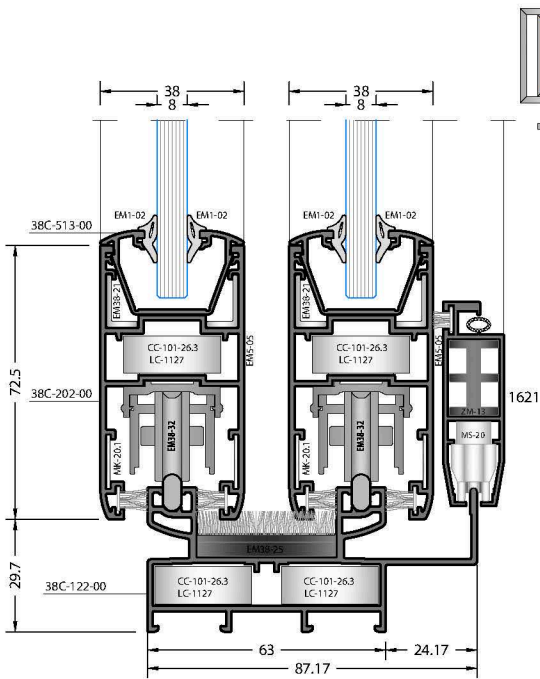
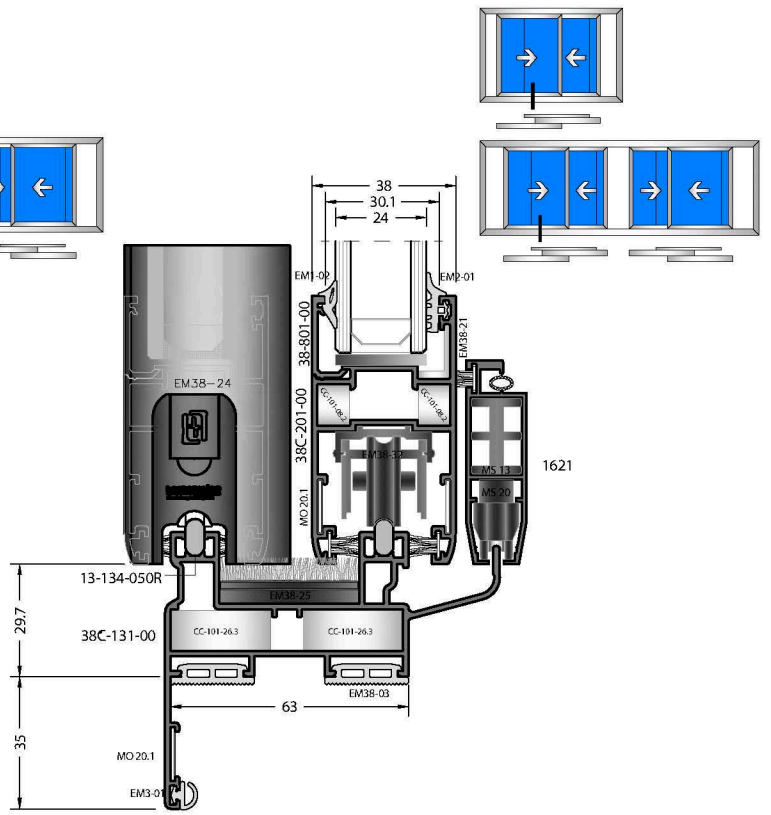
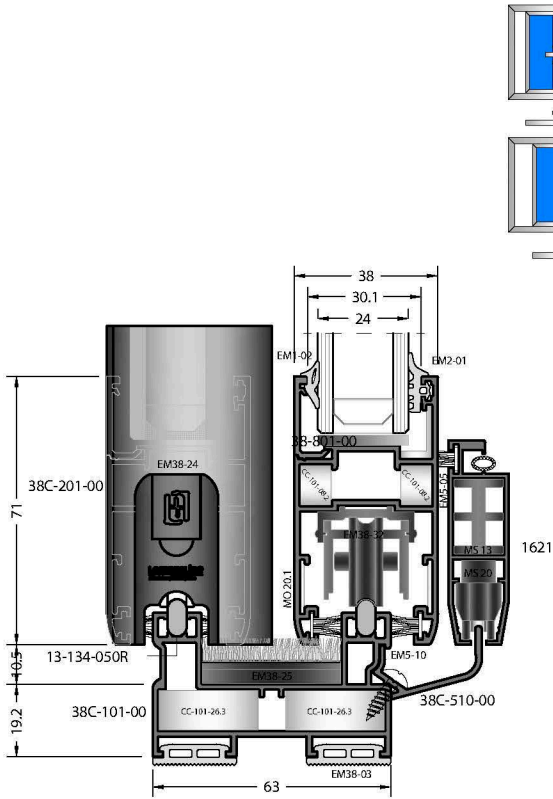

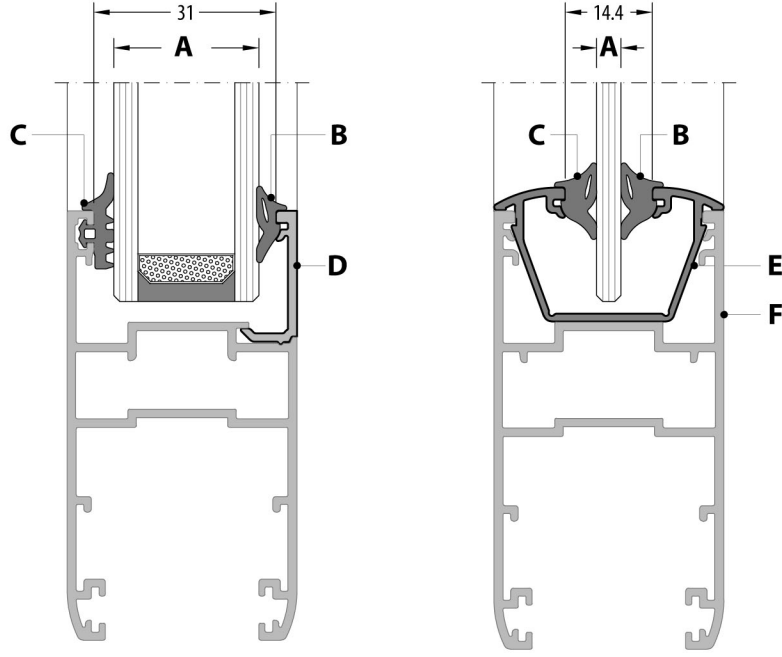

**38C SYSTEM / SİSTEM
ACCESSORIES / AKSESUARLAR**

GLAZING TABLE / CAM TABLOSU



A	B	C	D	E	F
GLAZING THICKNESS CAM KALINLIĞI	INSIDE GLASS GASKET İÇ CAM FİTİLİ	OUTSIDE GLASS GASKET DIŞ CAM FİTİLİ	GLAZING BEAD CAM ÇİTASI	ADAPTER ADAPTÖR	SASH KANAT
4 mm	EM1-04	EM2-01	38-808-00	-	38C-201-00
		EM1-04	-	38C-513-00	38C-202-00
5 mm	EM1-03	EM2-01	38-808-00	-	38C-201-00
6 mm	EM1-03	EM1-03	-	38C-513-00	38C-202-00
	EM1-02	EM2-01	38-808-00	-	38C-201-00
8 mm	EM1-02	EM1-02	-	38C-513-00	38C-202-00
	EM1-04	EM2-01	38-807-00	-	38C-201-00
9 mm	EM1-03	EM2-01	38-807-00	-	38C-201-00
10 mm	EM1-02	EM2-01	38-807-00	-	38C-201-00
20 mm	EM1-05	EM1-04	-	-	38C-202-00
	EM1-04	EM2-01	38-802-00	-	38C-201-00
22 mm	EM1-04	EM1-03	-	-	38C-202-00
		EM2-01	38-801-00	-	38C-201-00
24 mm	EM1-03	EM1-02	-	-	38C-202-00
	EM1-02	EM2-01	38-801-00	-	38C-201-00

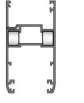

















PRESS CORNER JOINTS / PRES KÖŞE BAĞLANTILAR

ACCESSORY CODE AKSESUAR KOD	DRAWING ÇİZİM	PROFILE CODE PROFİL KOD	QUANTITY MIKTAR	CUTTING SIZE KESİM ÖLÇÜSÜ	APPLICATION PROFILES ÇALIŞTIĞI PROFİL	APPLICATION DETAIL UYGULAMA DETAY
CC-101-08.2		09-101-00	90 pieces adet	08.2 mm	38C-201-00	
CC-101-26.3		09-101-00	75 pieces adet	26.3 mm	38C-101-00	













CORNER JOINTS / KÖŞE BAĞLANTILAR

ACCESSORY CODE AKSESUAR KOD	DRAWING ÇİZİM	APPLICATION PROFILES ÇALIŞTIĞI PROFİL	APPLICATION DETAIL UYGULAMA DETAY
LC-1127		38C-101-00	
MK-20.1		38C-201-00	
EM38-21		38C-201-00	
ZM-13		1621 FOR FLY SCREEN SİNEKLİK	

GASKETS / FİTİLLER

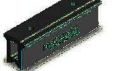
CODE KOD	DRAWING ÇİZİM	APPLICATION UYGULAMA	DESCRIPTION AÇIKLAMA	WEIGHT kg/m AĞIRLIK	PACKAGE QUANTITY PAKET MIKTARI
EM1-02			GLAZING GASKET INSIDE İÇ CAM FİTİLİ (EPDM)	0.050	300 m
EM1-04			GLAZING GASKET INSIDE İÇ CAM FİTİLİ (EPDM)	0.070	215 m
EM2-01			GLAZING GASKET OUTSIDE DIŞ CAM FİTİLİ (EPDM)	0.052	285 m
EM45-05			FRAME GASKET KASA FİTİLİ (EPDM)	0.030	500 m
EM38-03			FRAME GASKET KASA FİTİLİ (EPDM)	0.110	136 m
EM38-04			CLAMPING GASKET STANDARD KENET FİTİLİ - STANDART (EPDM)	0.148	101 m
EM38-05			ADAPTER GASKET ADAPTÖR FİTİLİ (EPDM)	0.210	71 m
EM5-05			BRUSH FİRÇA	-	350 m
EM5-10			BRUSH FİRÇA	-	300 m

ACCESSORIES / AKSESUARLAR

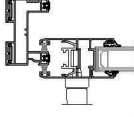
ACCESSORY CODE AKSESUAR KOD	DRAWING ÇİZİM	APPLICATION PROFILES ÇALIŞTIĞI PROFİL	PACKAGE QUANTITY PAKET MİKTARI	APPLICATION DETAIL UYGULAMA DETAY
EM38-91		EMBEDDING HANDLE AND STRIKER HAVUZ KOL VE KARŞILIĞI	SET / TAKIM	
EM38-32		PULLEY WITH 2 WHEELS SÜRME İKİLİ RULMAN (120 Kg)	PIECE / ADET	
MS-20		PULLEY (FOR FLY SCREEN) MAKARA (SİNEKLİK İÇİN)	PIECE / ADET	
EM38-23		STOPPER STOPER	PIECE / ADET	
EM38-22		SASH STABILITY ADAPTER TİTREŞİM TAKOZU	PIECE / ADET	
EM38-25		WEATHER STRIP HAVA KESİCİ	PIECE / ADET	
EM38-26		FIXED SASH ACCESSORY KANAT SABİTLEME TAKOZU	PIECE / ADET	
EM38-24		COVER CLIP - STANDARD ADAPTÖR KAPAĞI STANDART	SET / TAKIM	
EM38-51		PVC ESPAGNOLETTE PROFILE PVC İSPANYOLET PROFİLİ	6 - METERS 6 - METRE	

ACCESSORIES / AKSESUARLAR

ACCESSORY CODE AKSESUAR KOD	DRAWING ÇİZİM	APPLICATION PROFILES ÇALIŞTIĞI PROFİL	PACKAGE QUANTITY PAKET MİKTARI	APPLICATION DETAIL UYGULAMA DETAY
EM10-01 WHITE BEYAZ		DRAINAGE CAP TAHLİYE KAPAĞI	PIECE / ADET	
EM10-02 BLACK SİYAH				
EM10-03 BROWN KIRMIZI				
EM10-04 GRAY GRI				
EM10-05 LIGHT BLUE A. MAHİR				

**38C SYSTEM / SİSTEM
CUTTING SIZE / KESİM ÖLÇÜLERİ**

CUTTING SIZE / KESİM ÖLÇÜLERİ

SLIDE / SÜRME

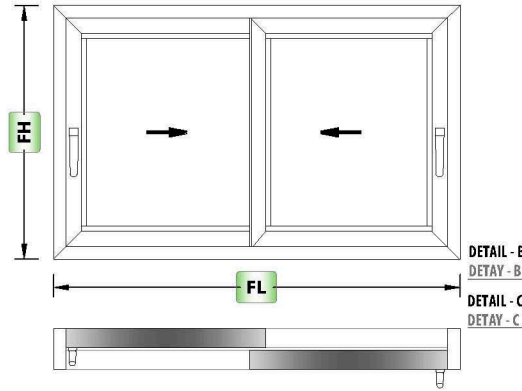

PROFILES / PROFİLLER

Code Kod	Drawing Çizim	Cut Kesim	Quantity Miktar	Dimensions (mm) Boyutlar	Mechanical Treatment Mekanik İşlem
38C-101-00			2 Pcs / Adet	FL	-
			2 Pcs / Adet	FH	-
38C-201-00			4 Pcs / Adet	$SL = \frac{(FL-59.4)}{2} + 32.5$	-
			4 Pcs / Adet	SH = FH - 59.4	-
08-801-00			4 Pcs / Adet	BL = SL - 100.2	-
08-802-00			4 Pcs / Adet	BH = SH - 142	-
08-808-00			4 Pcs / Adet	AH = SH	✓
38-502-00			2 Pcs / Adet	LR = FL - 63.8	-
13-134-050R			2 Pcs / Adet		-

GASKETS / FİTİLLER

Code Kod	Quantity Miktar	Picture Resim
EM1-XX	4SL+4SH	
EM2-01	4SL+4SH	
EM38-04	2SH	
EM38-03	4FL + 4FH	
EM45-05	2FL + 4FH	
EM5-10	8SL + 6SH	

CORNER JOINTS / KÖŞE BAĞLANTILAR

Code Kod	Quantity Miktar	Picture Resim
CC-101-26.3 Or / Yada LC-1127	8 Pcs / Adet	
CC-101-08.2	16 Pcs / Adet	
EM38-21	8 Pcs / Adet	
MK-20.1	16 Pcs / Adet	

CONSUMABLE MATERIALS / SARF MALZEMELER

Code Kod	Description Açıklama	Quantity (pcs-m) Miktar (Paket)	Picture Resim
EM38-91	EMBEDDING HANDLE AND STRIKER HAVUZ KOL VE KARŞILIĞI	2 Set / Takım	
EM38-23	STOPPER STOPER	4 Pcs / Adet	
EM38-32	PULLEY RULMAN	120 kg < 4 Pcs / Adet	
EM38-22	SASH STABILITY ADAPTER TİTREŞİM TAKOZU	4 Pcs / Adet	
EM38T-10	DRAINAGE CAP TAHLİYE KAPAĞI	2 Pcs / Adet	
EM38-24	COVER CLIP ADAPTÖR KAPAĞI	2 Set / Takım	
EM38-25	WEATHER STRIP HAVA KESİCİ	2 Pcs / Adet	

✓ Please look at the assembly drawings for mechanical treatment.
Mekanik işlemler için lütfen uygulama detayları bölümüne bakınız.

GLASS / CAM

Code Kod	Drawing Çizim	Quantity Miktar	Dimensions (mm) Boyutlar
Glass		2 Pcs / Adet	GL = SL - 112
Cam			GH = SH - 112

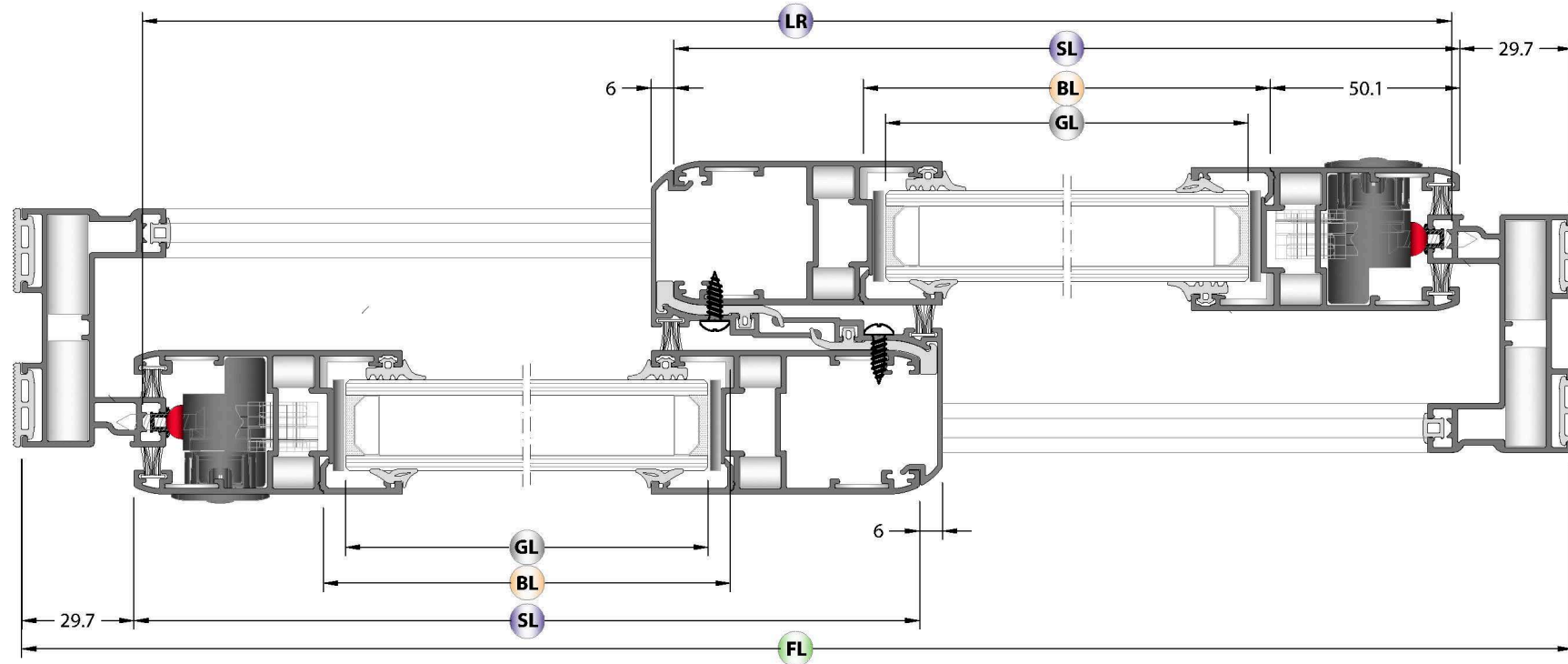
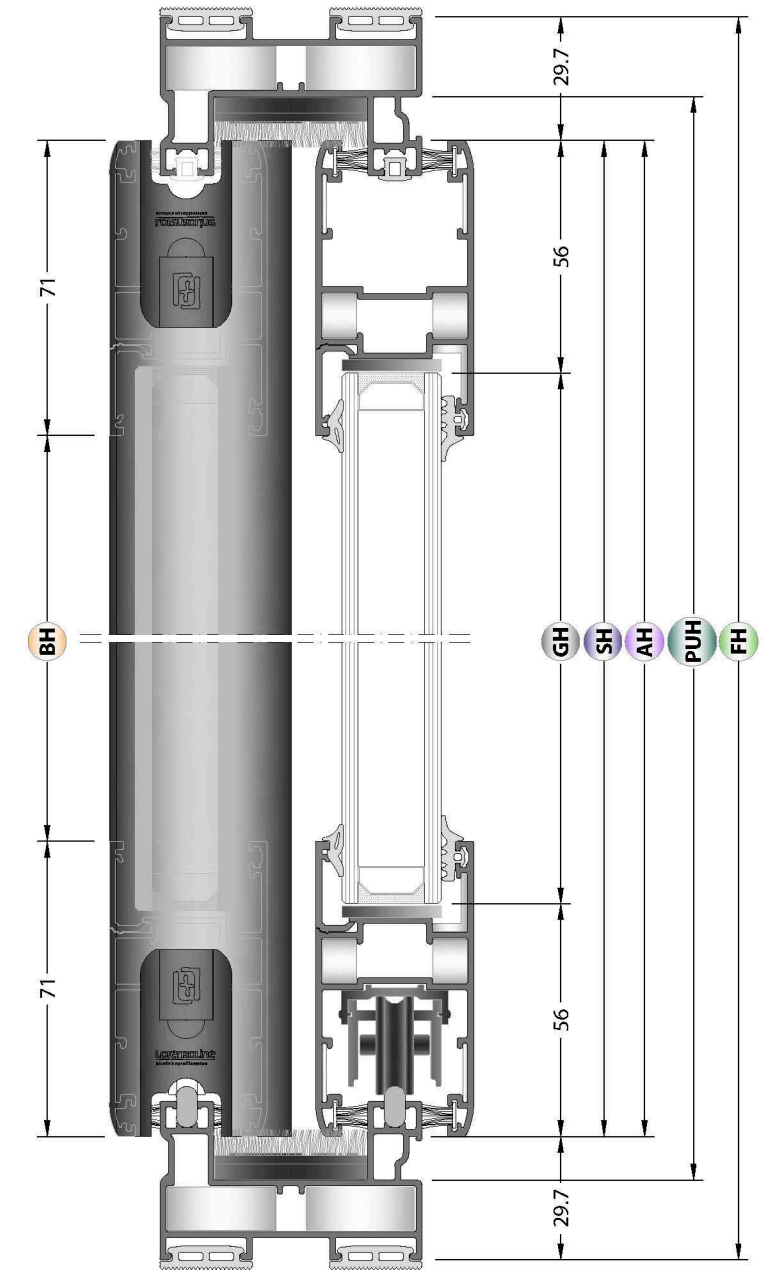

C DETAIL / C DETAYI

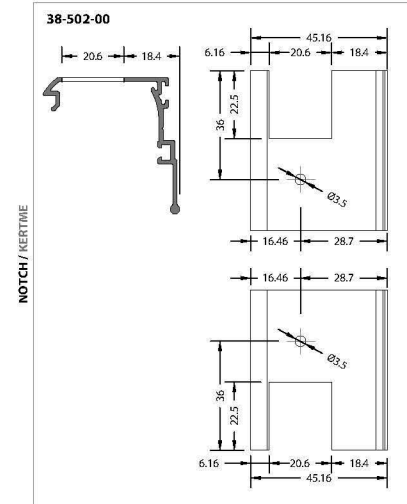

B DETAIL / B DETAYI

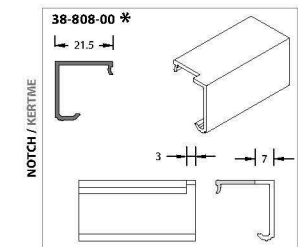

CUTTING SIZE / KESİM ÖLÇÜLERİ

SLIDE / SÜRME

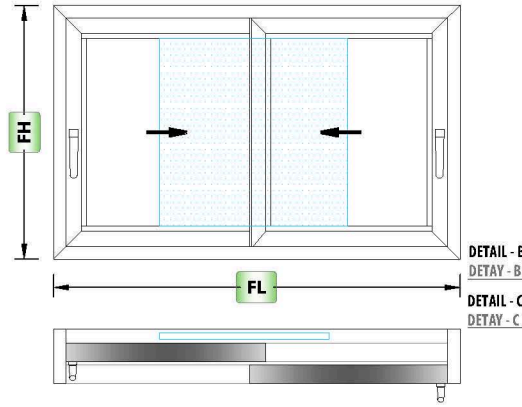

Code Kod	Drawing Çizim	Cut Kesim	Quantity Miktar	Dimensions (mm) Boyutlar	Mechanical Treatment Mekanik İşlem
38C-101-00			2 Pcs / Adet	FL	-
			2 Pcs / Adet	FH	-
38C-201-00			4 Pcs / Adet	$SL = \frac{(FL-59.4)}{2} + 32.5$	-
			4 Pcs / Adet	SH = FH - 59.4	-
08-801-00			4 Pcs / Adet	BL = SL - 100.2	-
08-802-00			4 Pcs / Adet	BH = SH - 142	-
08-808-00			4 Pcs / Adet	BH = SH - 142	-
38-502-00			2 Pcs / Adet	AH = SH	✓
13-134-050R			2 Pcs / Adet	LR = FL - 63.8	-
1621			2 Pcs / Adet	DL = SL + 6	-
			2 Pcs / Adet	DH = SH	-

✓ Please look at the assembly drawings for mechanical treatment.
Mekanik işlemler için lütfen uygulama detayları bölümüne bakınız.

GLASS / CAM

Code Kod	Drawing Çizim	Quantity Miktar	Dimensions (mm) Boyutlar
Glass Cam		2 Pcs / Adet	GL = SL - 112 GH = SH - 112

GASKETS / FİTİLLER

Code Kod	Quantity Miktar	Picture Resim
EM1-XX	4SL+4SH	
EM2-01	4SL+4SH	
EM38-04	2SH	
EM38-03	4FL + 4FH	
EM45-05	2FL + 4FH	
EM5-10	8SL + 6SH	
EM5-05	2DL + 2DH	

CORNER JOINTS / KÖŞE BAĞLANTILAR

Code Kod	Quantity Miktar	Picture Resim
CC-101-26.3 Or / Yada LC-1127	8 Pcs / Adet	
CC-101-08.2	16 Pcs / Adet	
EM38-21	8 Pcs / Adet	
MK-20.1	16 Pcs / Adet	
MS-13	4 Pcs / Adet	

CONSUMABLE MATERIALS / SARF MALZEMELER

Code Kod	Description Açıklama	Quantity (pcs-m) Miktar (Paket)	Picture Resim
EM38-91	EMBEDDING HANDLE AND STRIKER HAVUZ KOL VE KARŞILIĞI	2 Set / Takım	
EM38-23	STOPPER STOPER	4 Pcs / Adet	
EM38-32	PULLEY RULMAN	120 kg < 4 Pcs / Adet	
EM38-22	SASH STABILITY ADAPTER TITREŞİM TAKOZU	4 Pcs / Adet	
EM38T-10	DRAINAGE CAP TAHLİYE KAPAĞI	2 Pcs / Adet	
EM38-24	COVER CLIP ADAPTÖR KAPAĞI	2 Set / Takım	
EM38-25	WEATHER STRIP HAVA KESİCİ	2 Pcs / Adet	
MS-20	PULLEY (For Fly Screen) RULMAN (Sineklik için)	2 Pcs / Adet	
EM38T-510	FLY SCREEN RAIL CAP SİNEKLİK RAY KAPAĞI	2 Set / Takım	

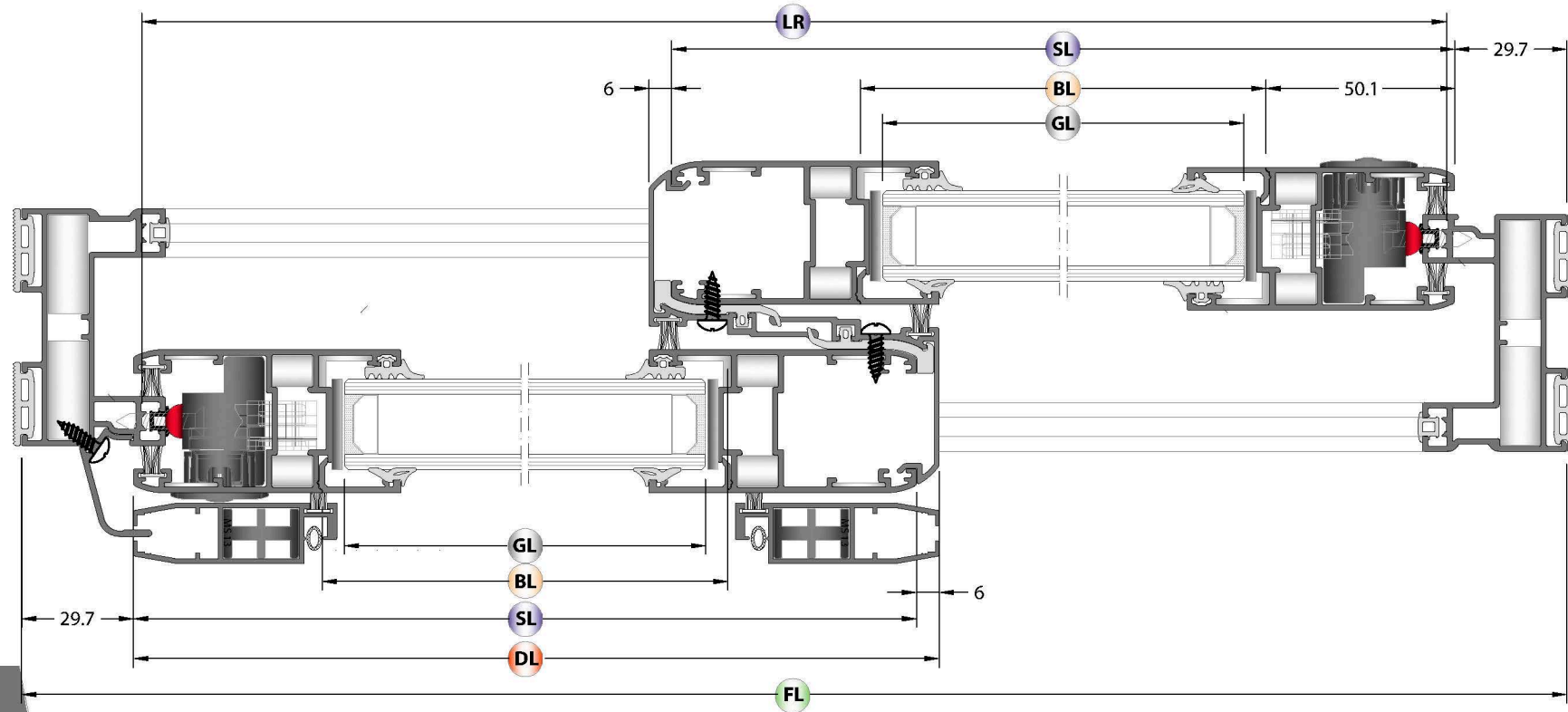
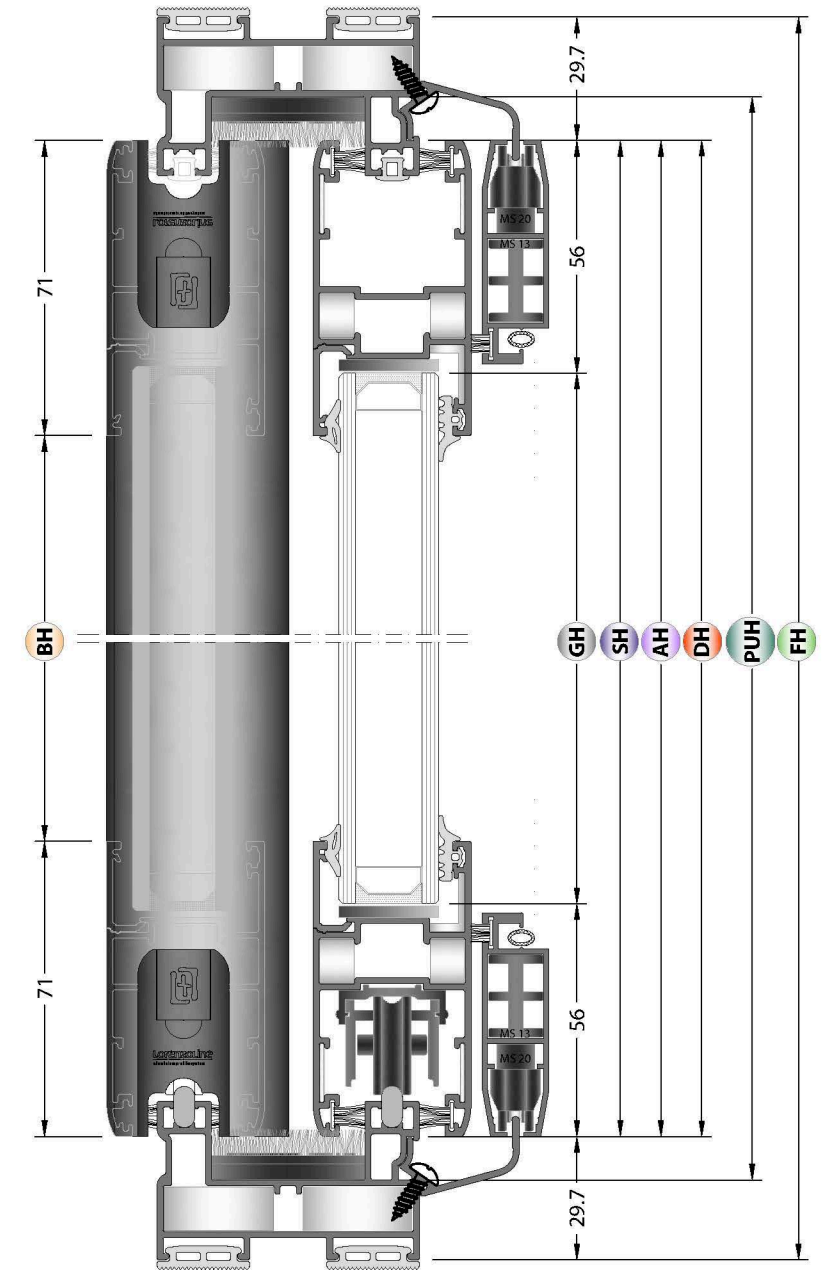

C DETAIL / C DETAYI

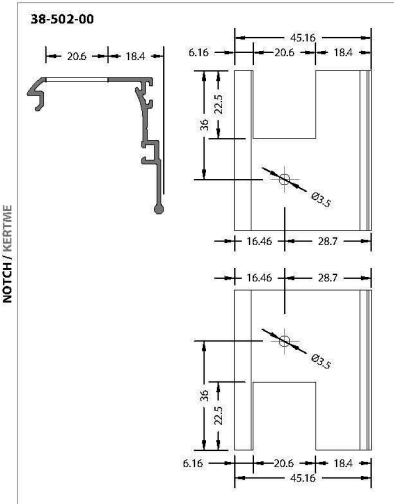

B DETAIL / B DETAYI

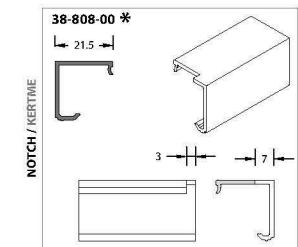

Produced by 

KURTOĞLU BAKIR KURŞUN SAN. A.Ş.
İstasyon Mah. Akbayır Mevkii Kümesi No: 81
Velimeşe - Çorlu 59851 Tekirdağ / TÜRKİYE
T: +90 282 684 70 00 F: +90 282 684 70 01
www.kurtogluas.com kurtoglu@kurtogluas.com

 **Lorenzoline**
aluminium profile system